

## BAL RATED DRAINAGE VENT & FLASHING KIT

### TECHNICAL DATA SHEET

SKU: VK50BAL12

- The metal pipe section and the perforated vent are made from 316 Stainless Steel (SS)
- The perforations provide ventilations area of equal to or greater than 1800mm<sup>2</sup> and holes do not exceed the 2mm diameter as specified in AS3959

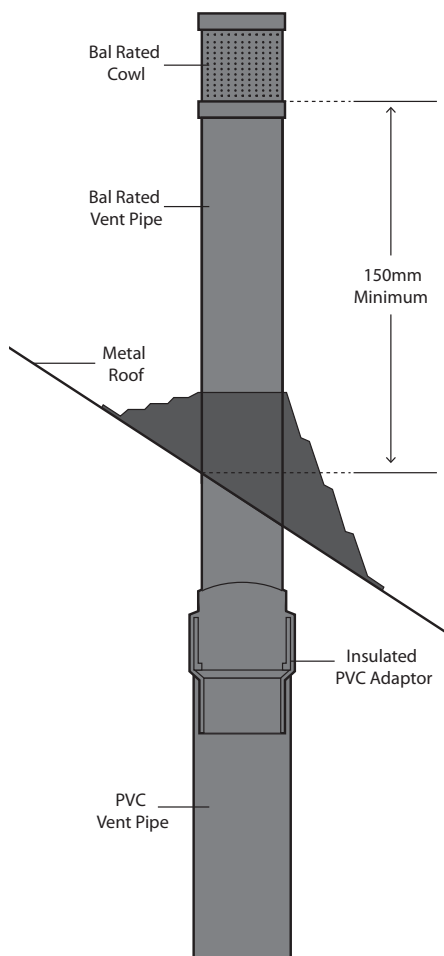

**316 SS Vent Pipe**

**Silicone Washers**

Shown here in red – have a temperature rating of 250°C. The two washer system insulates the PVC fitting from heat.

**PVC Vent Pipe**

SS pipe is sealed into PVC fitting using heat-resistant silicone.

PVC fitting is a UPVC material made to ASNZ1260 standard.

Kit includes an Aquarius Number 2 Black Aquaseal, pre-cut.



### INSTALLATION

1. Cut a hole in the roof large enough to allow the PVC adaptor to pass through.
2. Cut the PVC Vent pipe so that when assembled, the PVC to Steel Connector will be below the roof line. (Note: there needs to be a minimum of 150mm of solid vent pipe above the roof.)
3. Glue the PVC connector into the PVC vent pipe.
4. Pull the Aquaseal over the vent and seal it to the roof, using Roof and Gutter silicone.

<b>Colour</b>	Black
<b>Material</b>	EPDM
<b>Pipe range for 25° roof pitch</b>	50mm to 80mm
<b>Pipe range for 25° roof pitch</b>	50mm to 65mm
<b>Base size</b>	155mm x 155mm
<b>Temperature range</b>	-40°C (-40°F) to 115°C (239°F)

